

**General Description**

Series D\*1FB pilot operated proportional directional valves come in 4 sizes:

- D31FB NG10 (CETOP 5)
- D41FB NG16 (CETOP 7)
- D91FB NG25 (CETOP 8)
- D111FB NG32 (CETOP 10)

The valves are available with and without onboard electronics (OBE).

**D\*1FB OBE:** The digital onboard electronics is situated in a robust metal housing, which allows usage under rough environmental conditions.

The nominal values are factory set. The cable connection to a serial RS-232 interface is available as an accessory.

D\*1FB for external electronics: The parameters can be saved, changed and duplicated in combination with the digital power amplifier PWD00A-400.

Series D\*1FB valve parameters can be edited with the common ProPxD software for both versions.

The D\*1FB valves work with barometric feedback of the main stage to the pressure reducing pilot valve. The pilot control pressure of 25 Bar (363 PSI) allows high flow rates of maximum of stability.

The innovative integrated regenerative function into the A-line (optional) allows new energy saving circuits for differential cylinders. The hybrid version can be switched between regenerative mode and standard mode at any time.

**D91FB OBE**



D91FB



D91FB OBE

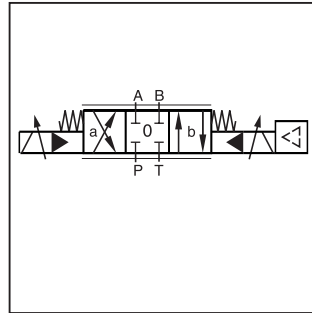

D\*1FB

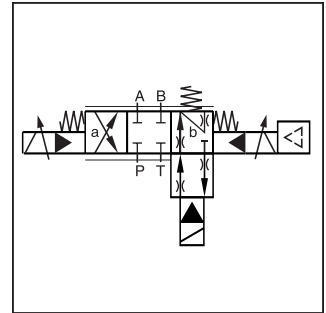

D\*1FBZ

**Features**

- Progressive flow characteristics for precise adjustment of flow rate
- High flow capacity
- Digital onboard electronics
- Center position monitoring optional
- New: Switchable regenerative hybrid version

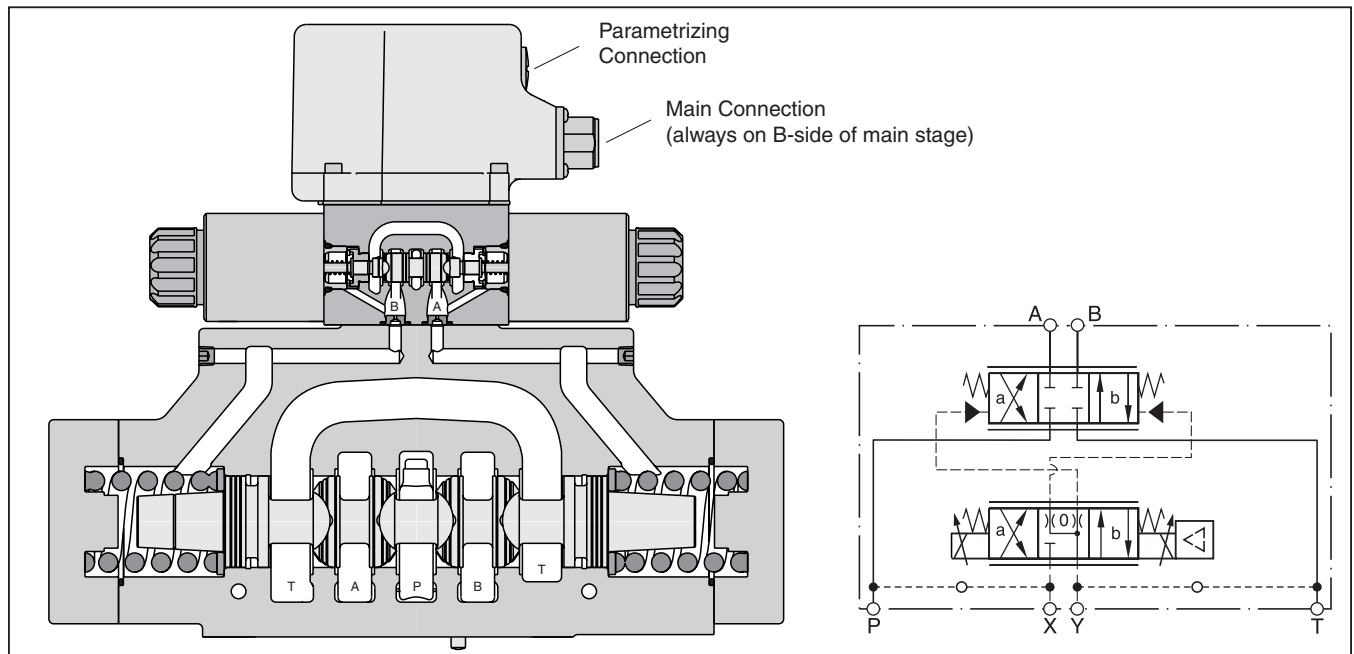

**WARNING:** This product can expose you to chemicals including Lead, Nickel (Metallic), or 1,3-Butadiene which are known to the State of California to cause cancer, and Lead or 1,3-Butadiene which is known to the State of California to cause birth defects and other reproductive harm. For more information go to [www.P65Warnings.ca.gov](http://www.P65Warnings.ca.gov).

A01\_Cat2500.indd, ddp, 04/19



**D\*1FBR and D\*1FBZ**

**A**

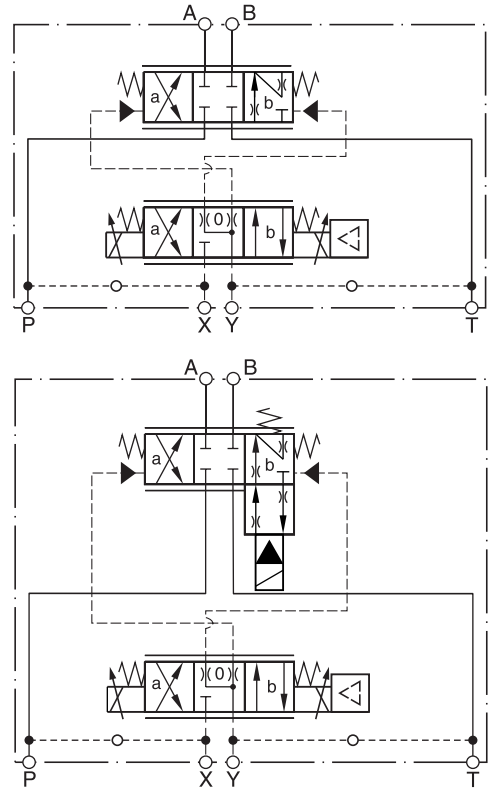
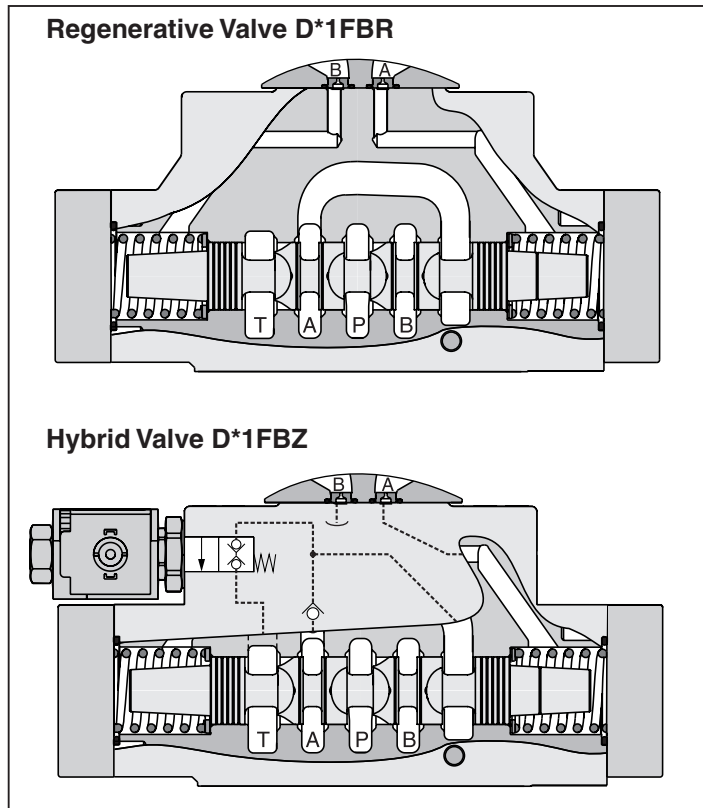

**D\*1FBR (Regenerative Valve)**

Cylinder extending

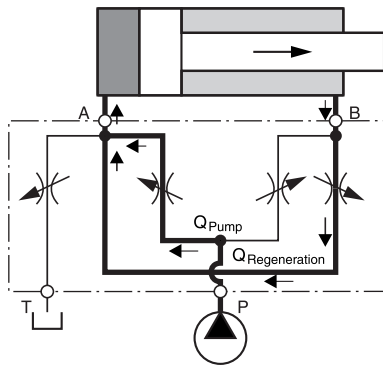

**D\*1FBZ (Hybrid Valve)**

Cylinder extending regenerative mode (high speed)

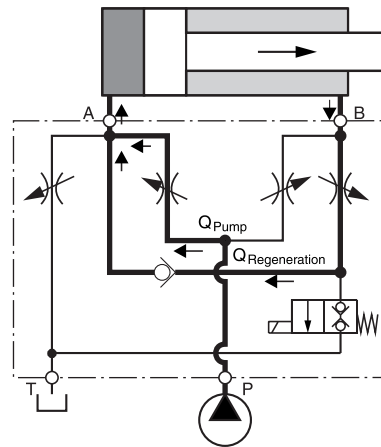

Cylinder extending standard mode (high force)

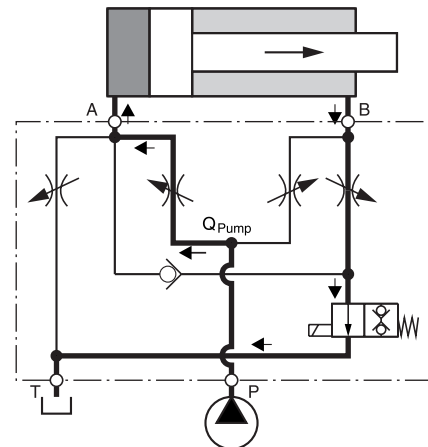

**Flow Rate in % of Nominal Flow**

Size	Spool	Port					
		A-T	P-A	P-B	B-A (R-Valve)	B-A (Hybrid)	B-T (Hybrid)
D41FBR/Z	31/32	100%	50%	100%	50%	45%	41 LPM (11 GPM) Max
D91FBR/Z	31/32	100%	50%	100%	50%	50%	98 LPM (26 GPM) Max
D111FBR/Z	31/32	100%	50%	100%	50%	50%	189 LPM (50 GPM) Max

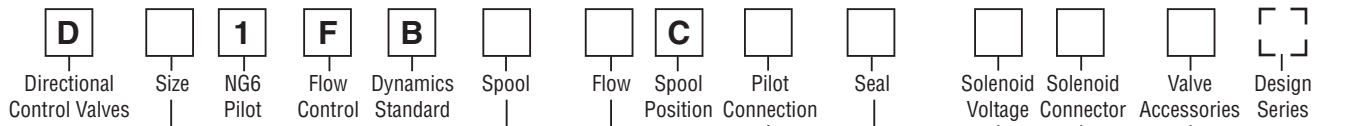

NOTE:  
 Not required when ordering.

Code	Description
3	NG10 / CETOP 5
4	NG16 / CETOP 7
9 <sup>1)</sup>	NG25 / CETOP 8
11	NG32 / CETOP 10

<sup>1)</sup> For enlarged connections  
 Ø 32 mm

Code	Description
N	Nitrile
V	Fluorocarbon

Code	Description
0	Standard
8 <sup>7)</sup>	Monitor Switch
L <sup>8)</sup>	Hybrid valve 24V normally closed for spool type Z

<sup>7)</sup> Not available for D111FBZ  
<sup>8)</sup> See page A48 for regenerative and hybrid spool information. (Not available in D31FB.)  
 Switch cover available, add -XG373 to part number.

Standard		NEW: Regenerative Function		NEW: Hybrid Function <sup>2)</sup>	
Code	Spool Type	Code	Spool Type	Code	Spool Type
E01					
E02					
B31	$Q_B = Q_A / 2$ 	R31		Z31	
B32	$Q_B = Q_A / 2$ 	R32		Z32	

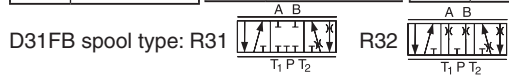

<sup>2)</sup> not available in D31FB.

Code	Inlet	Drain
1	Internal	External
2	External	External
4	Internal	Internal
5	External	Internal

Code	Description
W <sup>5)</sup>	Connector as per DIN 43650 without plug
J <sup>5) 6)</sup>	Connector DT04-2P "Deutsch"

<sup>5)</sup> Please order plugs separately. See Accessories.  
<sup>6)</sup> Not available with hybrid function.

Code	Solenoid
K	12V / 2.5A
J	24V / 1.1A

Code	Flow LPM (GPM) at Δp 5 Bar (72.5 PSI) per metering edge			
	D31	D41	D91	D111
B	—	100 <sup>3) 4)</sup> (26.4)	—	—
C	75 <sup>4)</sup> (19.8)	130 <sup>3) 4)</sup> (34.3)	—	—
D	90 <sup>4)</sup> (23.8)	—	—	—
E	120 (31.7)	—	250 <sup>3) 4)</sup> (66.0)	—
F	—	200 (52.8)	—	—
H	—	—	400 (105.7)	—
L	—	—	—	1000 (264.2)

<sup>3)</sup> Not available with spool type B31 und B32.  
<sup>4)</sup> Not available with regenerative or hybrid function.

**Bolt Kits:**

D31FB	BK98	(4) 1/4-20x1.625 SHCS
D41FB	BK160	(4) 3/8-16x2.5 SHCS (2) 1/4-20x2.5 SHCS
D91FB	BK228	(6) 1/2-13x3 SHCS
D111FB	BK150	(6) 3/4-10x3.5 SHCS

**Weight:**

D31FB	8.1 kg (17.9 lbs.)
D41FB	10.8 kg (23.8 lbs.)
D91FB	19.0 kg (41.9 lbs.)
D111FB	68.0 kg (149.9 lbs.)

General					
Design	Pilot operated DC valve				
Actuation	Proportional solenoid				
Size	NG10 (CETOP 5)	NG16 (CETOP 7)	NG25 (CETOP 8)	NG32 (CETOP 10)	
Mounting Interface	DIN 24340 / ISO 4401 / CETOP RP121 / NFPA				
Mounting Position	Unrestricted				
Ambient Temperature	[°C]	-20...+60; (-4°F...+140°F)			
MTTF <sub>D</sub> Value (OBE)	[years]	75 (50)			
Vibration Resistance	[g]	10 Sinus 5...2000 Hz acc. IEC 68-2-6 30 Random noise 20...2000 Hz acc. IEC 68-2-36 15 Shock acc. IEC 68-2-27			
Hydraulic					
Maximum Operating Pressure	Pilot Drain Internal: Ports P, A, B, X 350 Bar (5075 PSI); Port T, Y 185 Bar (2683 PSI) NG10: Port T, Y 15 Bar (218 PSI) Pilot Drain External: Ports P, A, B, T, X 350 Bar (5075 PSI); Port Y 185 Bar (2683 PSI) NG10: Port Y 15 Bar (218 PSI)				
Fluid	Hydraulic oil as per DIN 51524...51535, other on request				
Fluid Temperature	[°C]	-20...+60; (-4°F...+140°F)			
Viscosity					
Permitted	[cSt] / [mm <sup>2</sup> /s]	20...380 (93...1761 SSU)			
Recommended	[cSt] / [mm <sup>2</sup> /s]	30...80 (139...371 SSU)			
Filtration	ISO 4406 (1999) 18/16/13 (acc. NAS 1638: 7)				
Nominal Flow at Δp=Bar (72.5 PSI) per Control Edge *		D31FB	D41FB	D91FB	D111FB
		75 LPM (19.8 GPM)	100 LPM (26.4 GPM)	250 LPM (66.1 GPM)	1000 LPM (264.2 GPM)
		90 LPM (23.8 GPM)	130 LPM (34.4 GPM)	400 LPM (105.8 GPM)	
		120 LPM (31.7 GPM)	200 LPM (52.9 GPM)		
Leakage at 100 Bar (1450 PSI)	[ml/min]	100	200	600	1000
Pilot Supply Pressure	Minimum 30 Bar (435 PSI) [+T/Y pressure]; Maximum 350 Bar (5075 PSI) Optimal Dynamics at 50 Bar (725 PSI)				
Pilot Flow at 100 Bar (1450 PSI)		<0.5 LPM (0.13 GPM)	<1.2 LPM (0.3 GPM)	<1.2 LPM (0.3 GPM)	<1.2 LPM (0.3 GPM)
Pilot Flow, Step Response		2 LPM (0.5 GPM)	1.9 LPM (0.5 GPM)	4.5 LPM (1.2 GPM)	18 LPM (4.8 GPM)
Static / Dynamic					
Step Response at 100% Step	[ms]	50	75	100	180
Hysteresis	[%]	≤5			
Electrical					
Duty Ratio	[%]	100 ED; CAUTION: Coil temperature up to 150°C (302°F) possible			
Protection Class	Standard (as per EN175301-803) IP65 in accordance with EN60529 (plugged and mounted) DT04-2P "Deutsch" IP69K (plugged and mounted)				
Solenoid		Code "K"		Code "J"	
Supply Voltage	[V]	12		24	
Current Consumption	[A]	2.5		1.1	
Resistance	[Ohm]	4.4		18.6	
Coil Insulation Class	F (155 °C); (331°F)				
Solenoid Connection	Connector as per EN 175301-803 (code W), DT04-2P "Deutsch" connector (code J). Solenoid identification as per ISO 9461.				
Wiring Minimum	[mm <sup>2</sup> ]	3x1.5 (AWG 16) overall braid shield			
Wiring Length Maximum	[m]	50 (164 ft.)			

\* Flow rate for different Δp per control edge:  $Q_x = Q_{Nom.} \cdot \sqrt{\frac{\Delta p_x}{\Delta p_{Nom.}}}$

Continued on next page

A

Electrical Monitor Switch (Offboard Electronics)		
Protection Class		IP65 in accordance with EN 60529 (plugged and mounted)
Ambient Temperature	[°C]	0...70; (32°F...158°F)
Supply Voltage/Ripple	[V]	18...42, ripple <10% eff.
Current Consumption without Load	[mA]	<30
Maximum Output Current per Channel, Ohmic	[mA]	400
Minimum Output Load per Channel, Ohmic	[kOhm]	100
Max. output drop at 0.2A	[V]	<1.1
Max. output drop at 0.4A	[V]	<1.6
EMV		EN 50081-1 / EN50082-2
Maximum tol. Ambient Field Strength	[A/m]	1200
Minimum Distance to next AC Solenoid	[m]	0.1 (0.2 ft.)
Interface		4+PE acc. IEC 61076-2-101 (M12)
Wiring Minimum	[mm²]	5x0.5 (AWG 20) overall braid shield
Wiring Length Maximum	[m]	50 (164 ft.)

Electrical (Onboard Electronics)		
Duty Ratio	[%]	100 ED; CAUTION: Coil temperature up to 150°C (302°F) possible
Protection Class		IP65 in accordance with EN 60529 (plugged and mounted)
Supply Voltage/ripple DC	[V]	18...30, ripple < 5% eff., surge free
Current Consumption Maximum	[A]	2.0
Pre-fusing Medium Lag	[A]	2.5
Input Signal		
Codes F0, M0 & W5 Voltage	[V]	+10...0...-10, ripple < 0.01 % eff., surge free, Ri = 100kOhm, 0...+10V
Codes S0 & W5 Current	[mA]	4...12...20, ripple < 0.01 % eff., surge free, Ri = 200Ohm, 12...20mA < 3.6 mA = enable off, > 3.8 mA = enable on (acc. to NAMUR NE43)
Code G0	[mA]	+20...0...-20, ripple < 0.01 % eff., surge free, Ri = 200Ohm, 0...+20mA
Differential Input Maximum		
Codes F0, G0, M0 & S0	[V]	30 for terminal D and E against PE (terminal G) 11 for terminal D and E against 0V (terminal B)
Code W5	[V]	30 for terminal 4 and 5 against PE (terminal PE) 11 for terminal 4 and 5 against 0V (terminal 2)
Voltage References:		Not a powered output Only for 10K Ohm pots
Channel Recall Signal	[V]	0...2.5: off / 5...30: on / Ri = 100 kOhm
Adjustment Ranges:		
Minimum	[%]	0...50
Maximum	[%]	50...100
Ramp	[s]	0...32.5
Interface		RS-232, parametrizing connection 5 pole
EMC		EN 61000-6-2, EN 61000-6-4
Central Connection		
Codes F0, G0 & S0		6 + PE acc. to EN 175201-804
Code W5		11 + PE acc. to EN 175201-804
Wiring Minimum		
Codes F0, G0 & S0	[mm²]	7 x 1.0 (AWG16) overall braid shield
Code W5	[mm²]	11 x 1.0 (AWG20) overall braid shield
Wiring Length Maximum	[m]	50 (164 ft.)

Continued on next page



**Specifications (cont.)**

Electrical (Hybrid Option)			
Duty Ratio	[%]	100 ED; CAUTION: Coil temperature up to 150°C (302°F) possible	
Protection Class		IP65 in accordance with EN 60529 (plugged and mounted)	
		<b>D41</b>	<b>D91</b>
Supply Voltage	[V]	24	24
Tolerance Supply Voltage	[%]	±10	±10
Current Consumption	[A]	1.21	0.96
Power Consumption	[W]	29	23
Solenoid Connection		Connector as per EN 175301-803	
Wiring Minimum	[mm <sup>2</sup> ]	3 x 1.5 recommended	
Wiring Length Maximum	[m]	50 (164 ft.) recommended	

With electrical connections the protective conductor (PE ↓) must be connected according to the relevant regulations.

**Performance Curves**

**D\*1FB Flow**

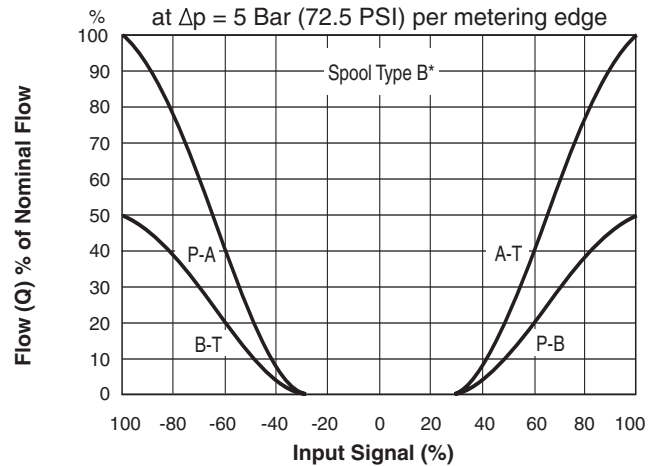
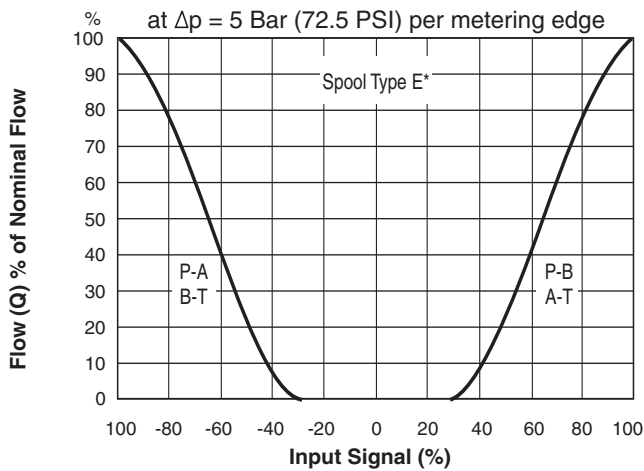

All performance curves measured with HLP46 at 50°C (122°F).

**D\*1FB OBE Flow**

(Electrically set to opening point 10%)

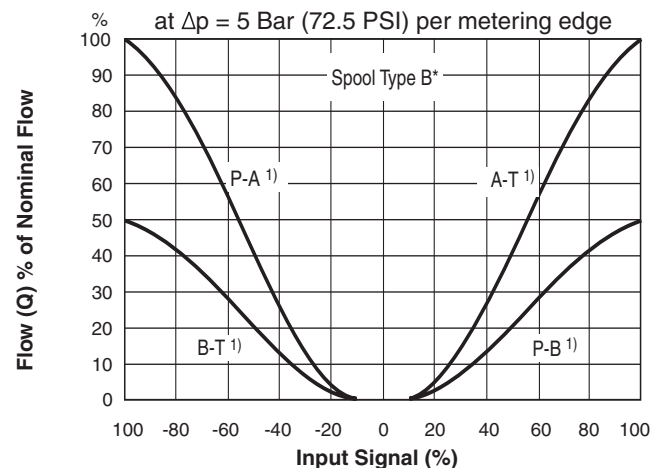
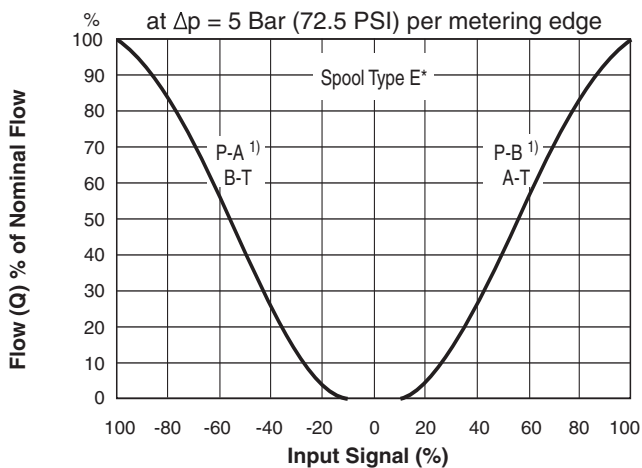

All performance curves measured with HLP46 at 50°C (122°F).

<sup>1)</sup> Flow direction depending on ordering code.

**D\*1FB R/Z (Regenerative and Hybrid)**

**A**

**D41FB R/Z**

**D91FB R/Z**

Spool Code **R/Z31/32**

Spool Code **R/Z31/32**

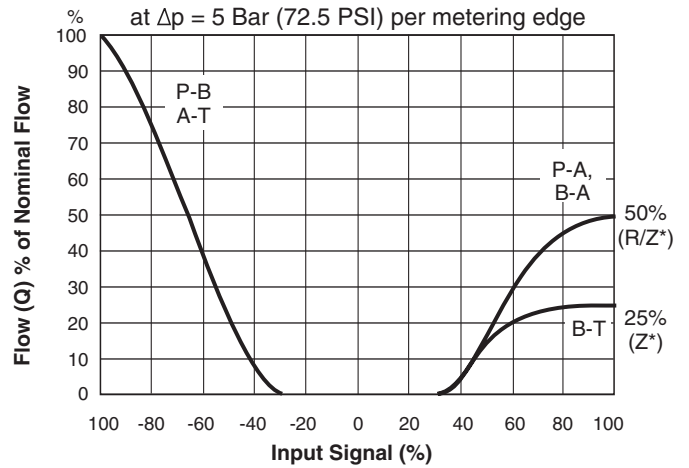
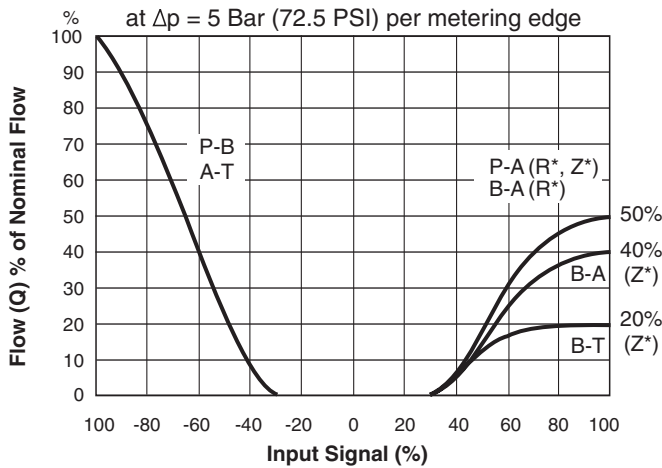

All performance curves measured with HLP46 at 50°C (122°F).

**D41FB R/Z OBE**

**D91FB R/Z OBE**

Spool Code **R/Z31/32**

Spool Code **R/Z31/32**

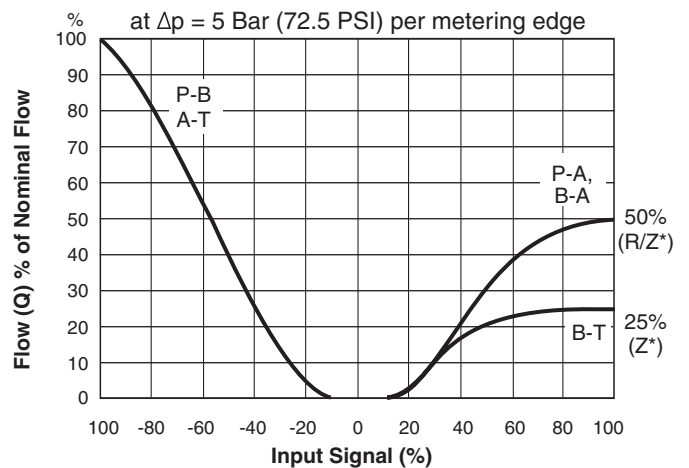
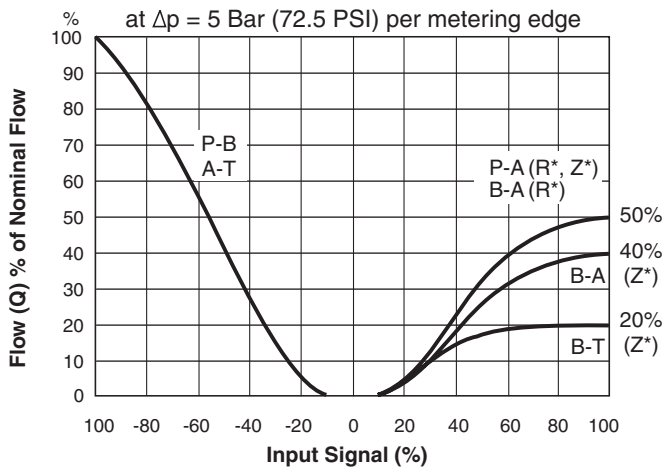

All performance curves measured with HLP46 at 50°C (122°F).

**Monitor Switch M12x1 Pin Assignment**

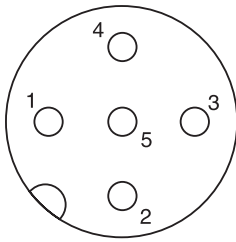

- 1 + Supply 18...42V
- 2 Output B (normally closed)
- 3 0V
- 4 Output A (normally closed)
- 5 Earth ground

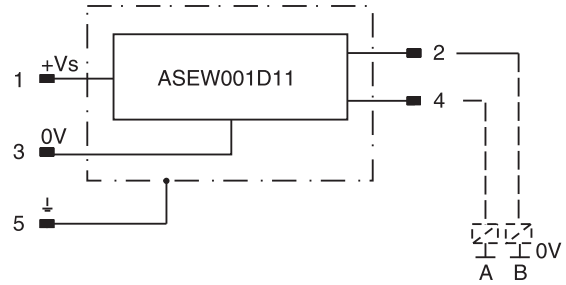

Signal	Output A (pin 4)	Output B (pin 2)
neutral	closed	closed
	open	closed
	closed	open

The neutral position is monitored. The signal changes after less than 10% of the spool stroke.

**Electrical Monitor Switch**

Protection Class	IP65 in accordance with EN 60529 (plugged and mounted)
Ambient Temperature	[°C] 0...70; (32°F...158°F)
Supply Voltage/Ripple	[V] 18...42, ripple < 10% eff.
Current Consumption without Load	[mA] < 30
Maximum Output Current per Channel, Ohmic	[mA] 400
Minimum Output Load per Channel, Ohmic	[kOhm] 100
Maximum Output Drop at 0.2A	[V] < 1.1
Maximum Output Drop at 0.4A	[V] < 1.6
EMC	EN 50081-1, EN50082-2
Maximum tol. Ambient Field Strength	[A/m] 1200
Minimum Distance to Next AC solenoid	[m] 0.1
Interface	4+PE acc. IEC 61076-2-101 (M12)
Wiring Minimum	[mm²] 5 x 0.5 (AWG 20) overall braid shield
Wiring Length Maximum	[m] 50 (164 ft.)



**A**

**Code F0, M0**  
**6 + PE acc. to EN 175201-804**

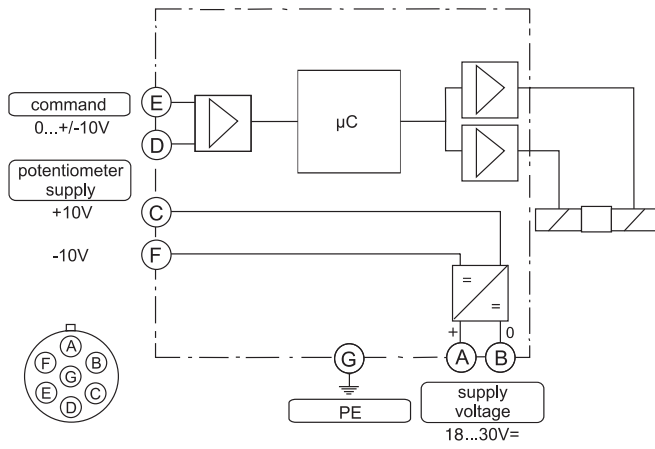

**Code G0, S0**  
**6 + PE acc. to EN 175201-804**

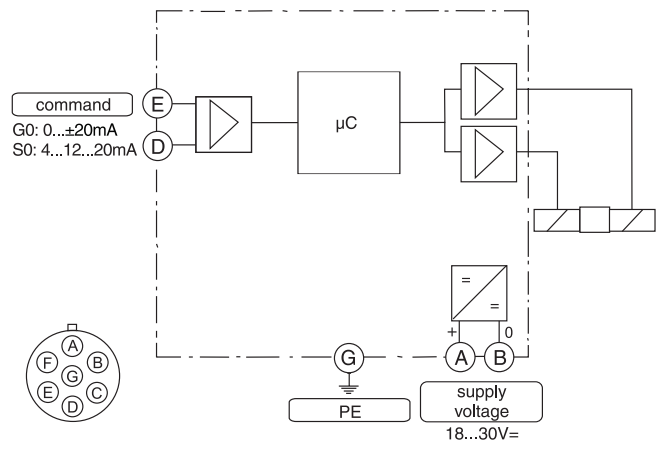

**Code W5**  
**11 + PE acc. to EN 175201-804**

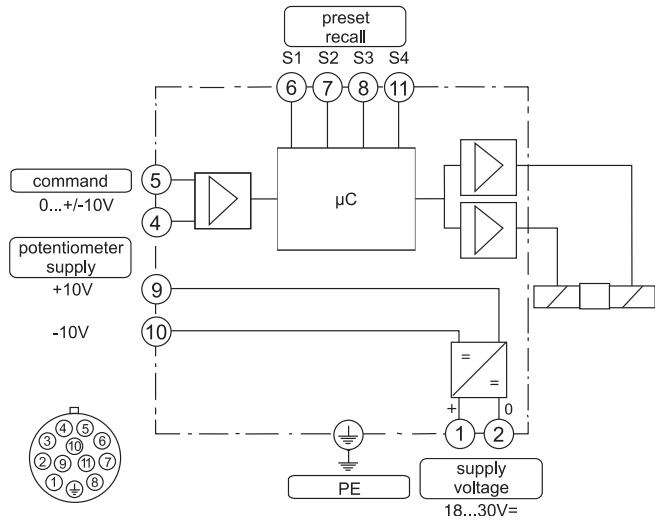



**ProPxD Interface Program**

The ProPxD software allows quick and easy setting of the digital valve electronics. Individual parameters as well as complete settings can be viewed, changed and saved via the comfortable user interface. Parameter sets saved in the non-volatile memory can be loaded to other valves of the same type or printed out for documentation purposes.

**Features**

- Simple editing of all parameters.
- Storage and loading of optimized parameter adjustments.
- Executable with all Windows® operating systems from Windows® 95 upwards.
- Communication between PC and electronics via serial interface RS-232.

The valve electronics cannot be connected to a PC with a standard USB cable – this can result in damages of PC and/or valve electronics.

Simple to use interface program. Download free of charge [www.parker.com/propxd](http://www.parker.com/propxd)

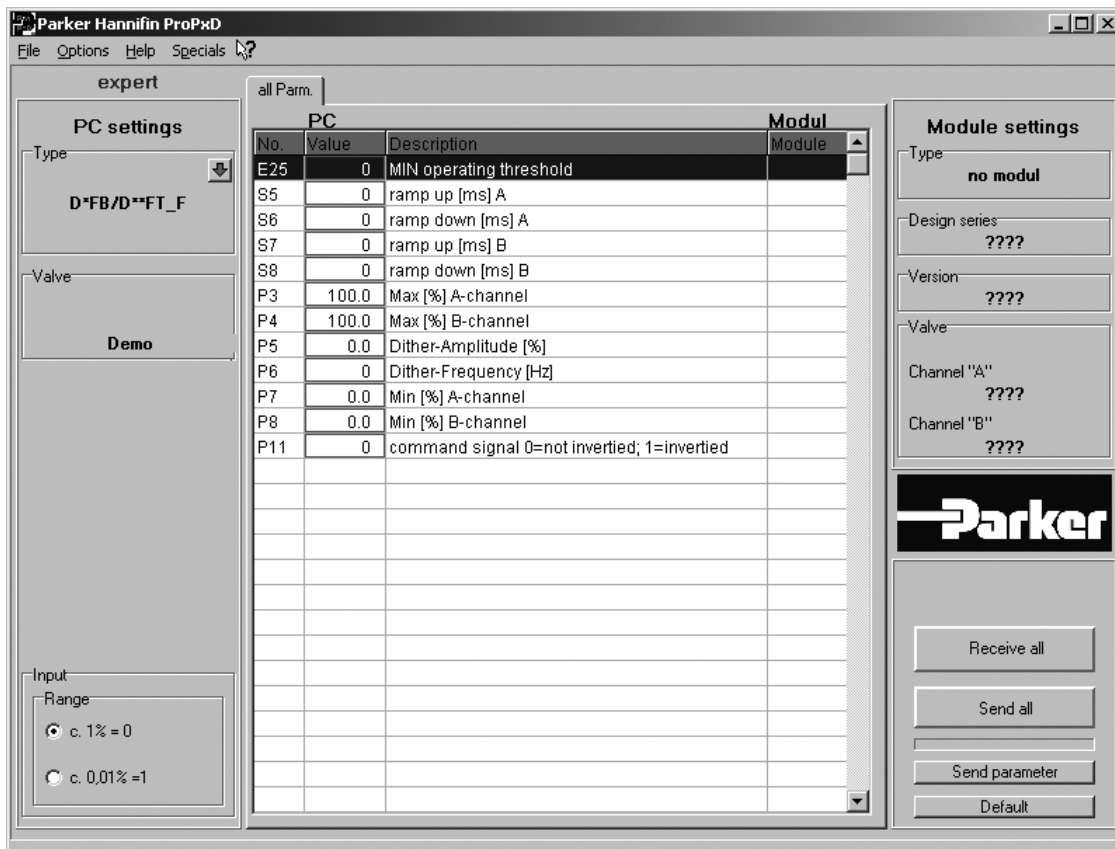

The parametrizing cable may be ordered under item no. 40982923.

**Pilot Flow — Pilot Oil Inlet (Supply) and Outlet (Drain)**

○ open, ● closed

Pilot oil		B	C
Inlet	Drain		
internal	external	○	●
external	external	●	●
internal	internal	○	○
external	internal	●	○

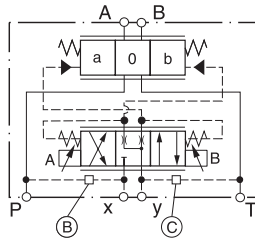

**A**

**D31FBB/E D31FBR**

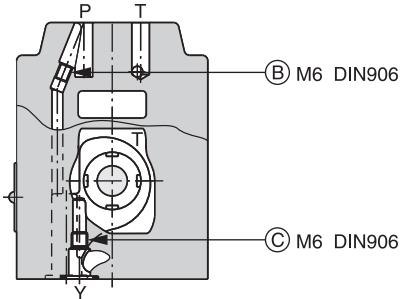

(drawn offset)

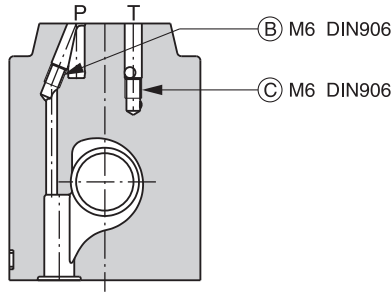

**D41FBB/E D41FBR**

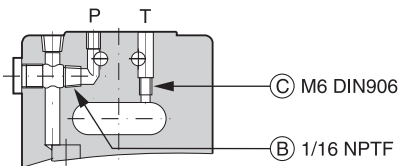

**D41FBZ**

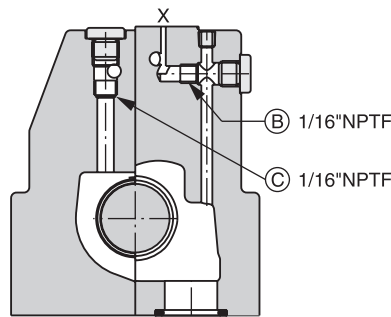

(drawn offset)

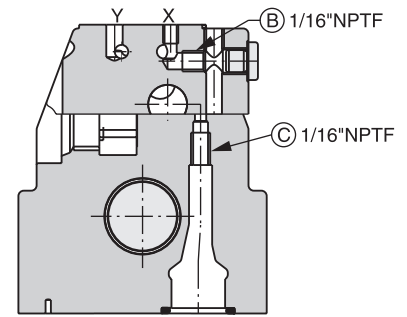

(drawn offset)

**D91FBB/E D91FBR**

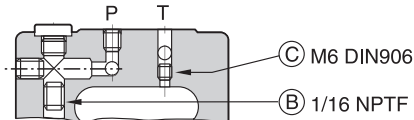

**D91FBZ**

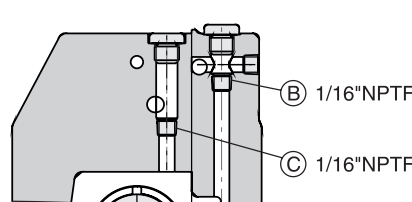

(drawn offset)

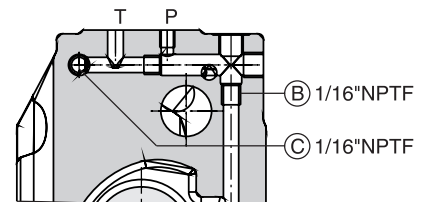

**D111FBB/E D111FBR**

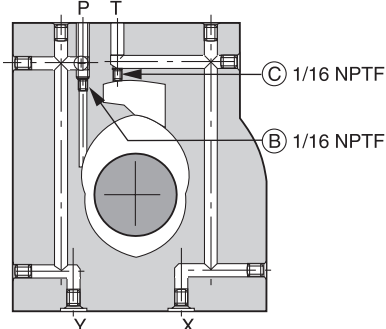

**D111FBZ**

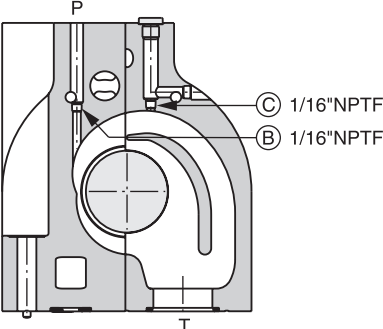

(drawn offset)

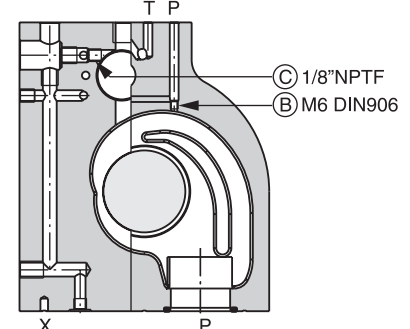

(drawn offset)

**Dimensions**

**Proportional Directional Control Valves  
Series D\*1FB (Offboard Electronics)**

Inch equivalents for millimeter dimensions are shown in (\*\*)

**D31FB**

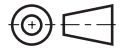
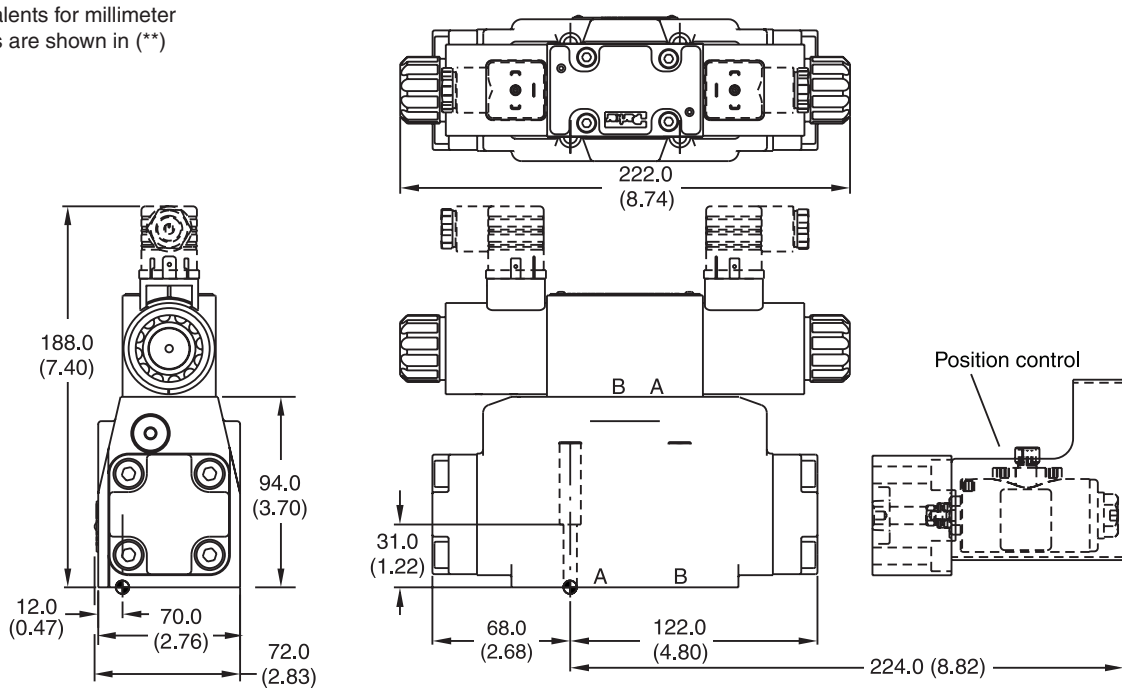

Surface Finish	Kit	Kit	Kit	Seal Kit
	BK385	4x M6x40 DIN 912 12.9	13.2 Nm (9.7 lb.-ft.) ±15 %	Nitrile: SK-D31FB Fluorocarbon: SK-D31FBV
	BK98	4x 1/4-20x1.62		

**D41FB**

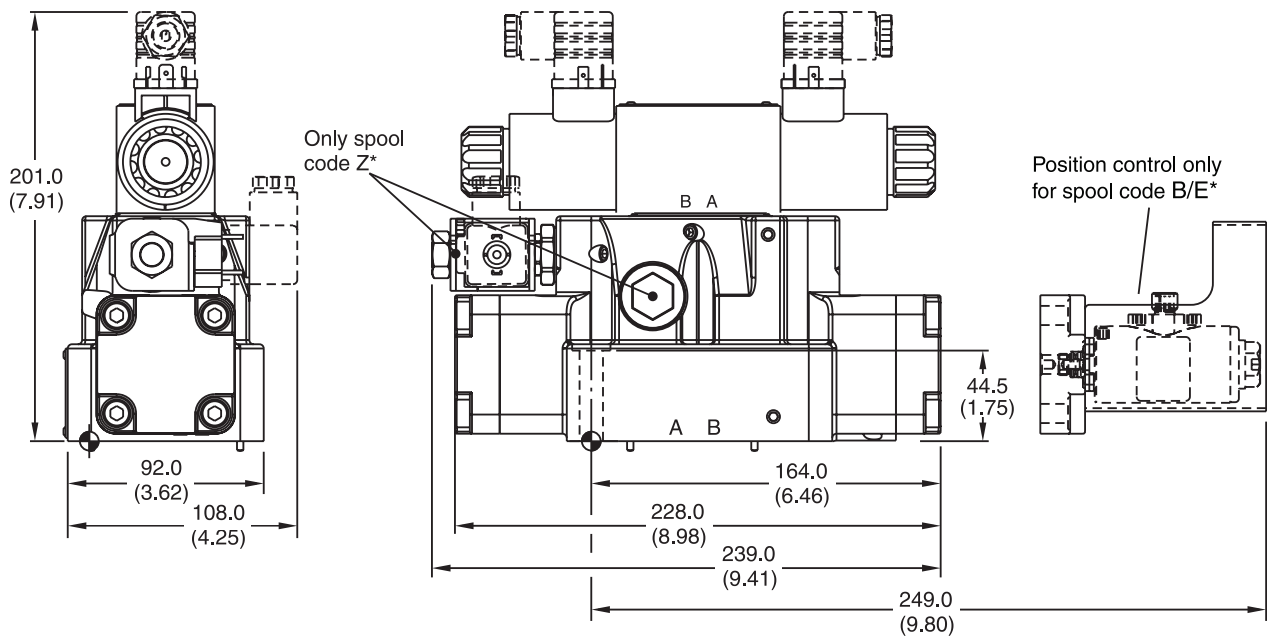

Surface Finish	Kit	Kit	Kit	Seal Kit
	BK320	2x M6x55 4x M10x60 DIN 912 12.9	13.2 Nm (9.7 lb.-ft.) 63 Nm (46.5 lb.-ft.) ±15 %	Nitrile: SK-D41FB Fluorocarbon: SK-D41FBV
	BK160	4x 3/8-16x2.5 2x 1/4-20x2.5		

Inch equivalents for millimeter dimensions are shown in (\*\*)



**D91FB**

**A**

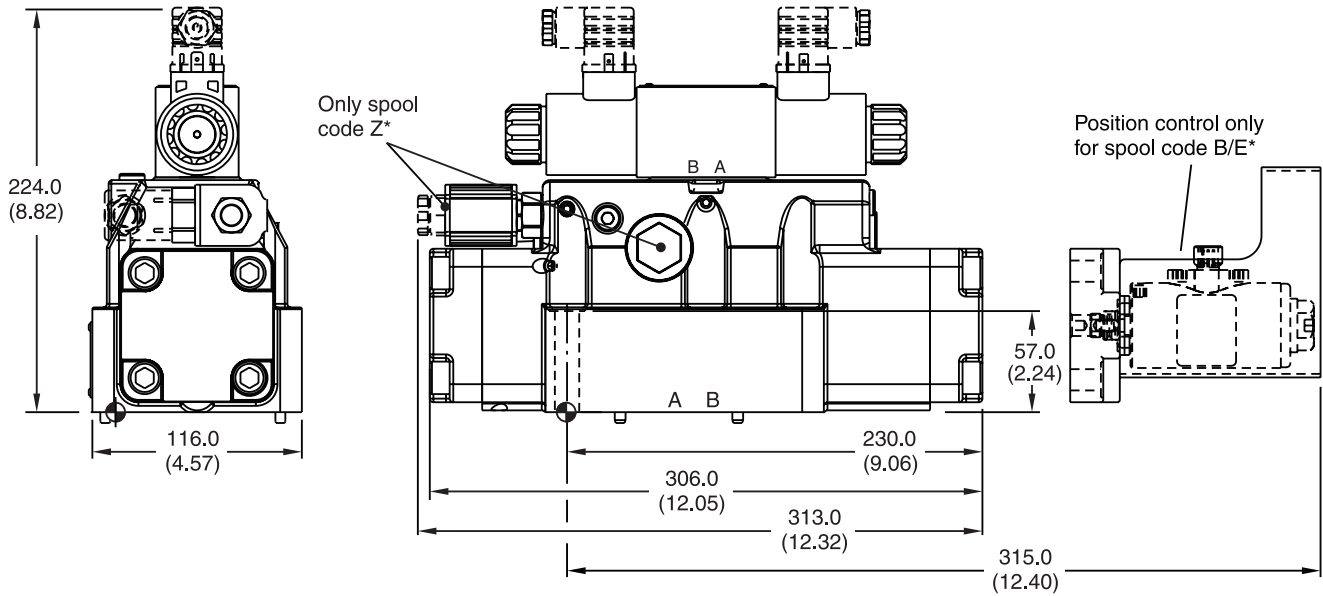

Surface Finish	Kit	Kit	Torque	Seal  Kit
	BK360 BK228	6x M12x75 DIN 912 12.9 6x 1/2-13x3.0	108 Nm (79.7 lb.-ft.) ±15 %	Nitrile: SK-D91FB Fluorocarbon: SK-D91FBV

**Dimensions**

**Proportional Directional Control Valves  
Series D\*1FB**

Inch equivalents for millimeter dimensions are shown in (\*\*)

**D111FB**

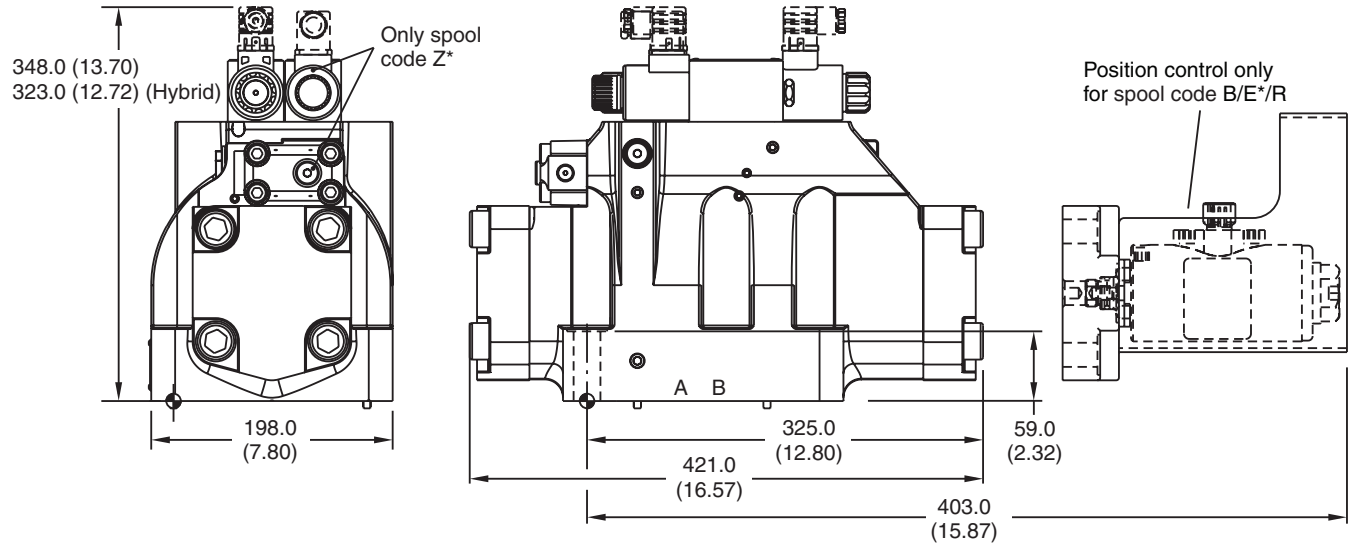

Surface Finish	Kit	Wrench	Torque	Seal Kit
	BK386 BK150	6x M20x90 DIN 912 12.9 6x 3/4-10x3.5	517 Nm (373.9 lb.-ft.) ±15 %	Nitrile: SK-D111FB Fluorocarbon: SK-D111FBV

**Dimension with DT04-2P "Deutsch" Connector**

